

# CONSTRUCTION OF A LOW-SPEED CLOSED-RETURN WIND TUNNEL

Jon Durbin and Dr. Kurt Aikens

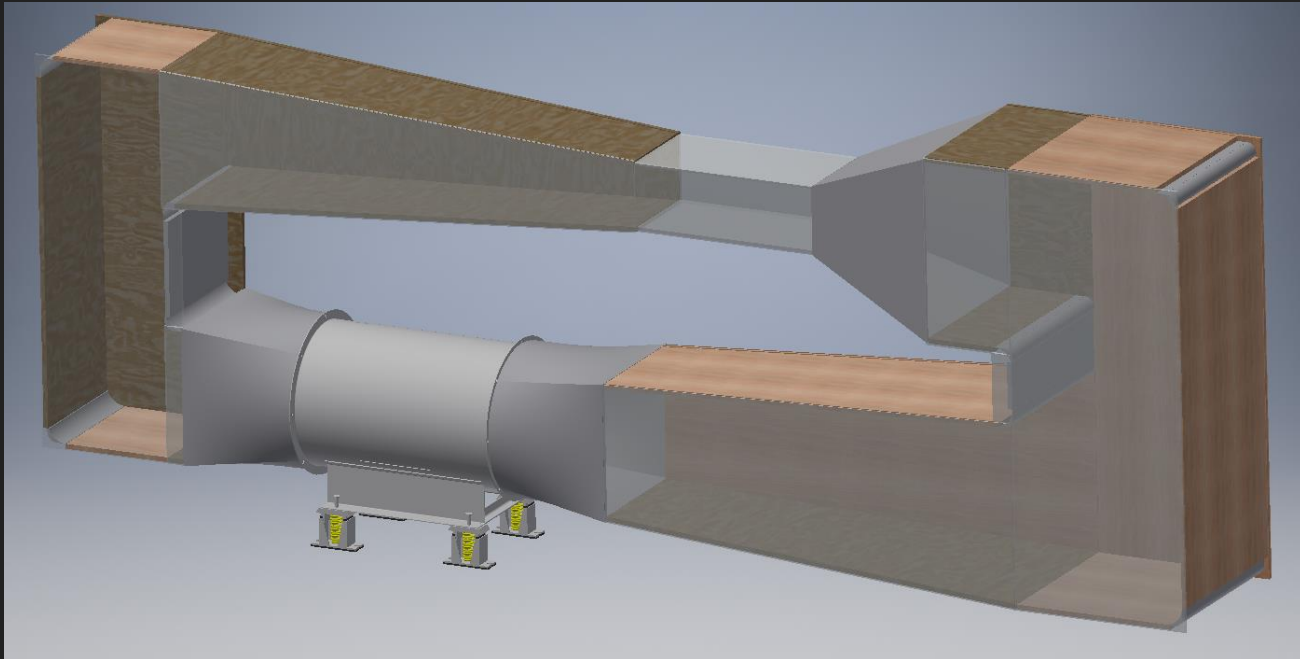

# Motivation

Wind tunnel at Houghton College

Student research

Laboratories

Important tool for fluid dynamicists

My project:

Refine overall design

Build parts



# Overview

Theory

General Wind Tunnel

Houghton's Wind Tunnel

Design Considerations

Current Progress

Conclusions

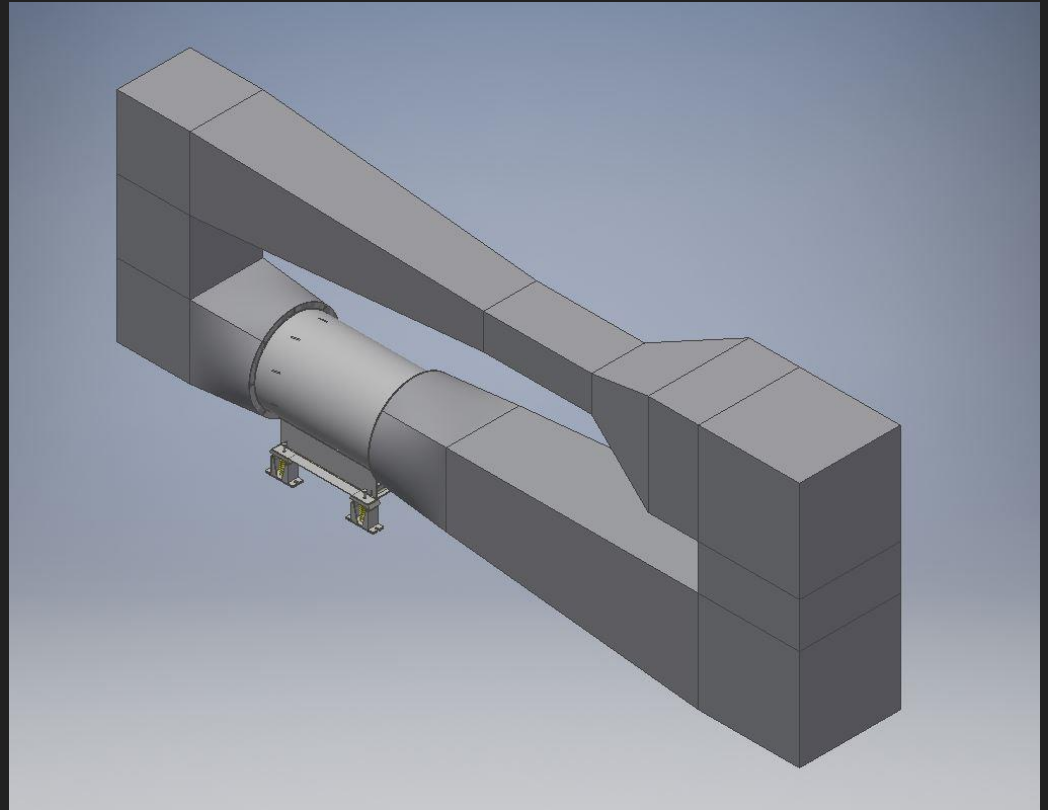

# Governing Equations

Continuity equation and Navier-Stokes equations:

$$\frac{\partial \rho}{\partial t} + \frac{\partial}{\partial x_k} (\rho u_k) = 0$$

$$\frac{\partial(\rho u_j)}{\partial t} + \frac{\partial(\rho u_j u_k)}{\partial x_k} = \frac{\partial}{\partial x_i} \left\{ -p \delta_{ij} + \mu \left( \frac{\partial u_i}{\partial x_j} + \frac{\partial u_j}{\partial x_i} - \delta_{ij} \frac{2}{3} \frac{\partial u_k}{\partial x_k} \right) \right\}$$

# General Wind Tunnel

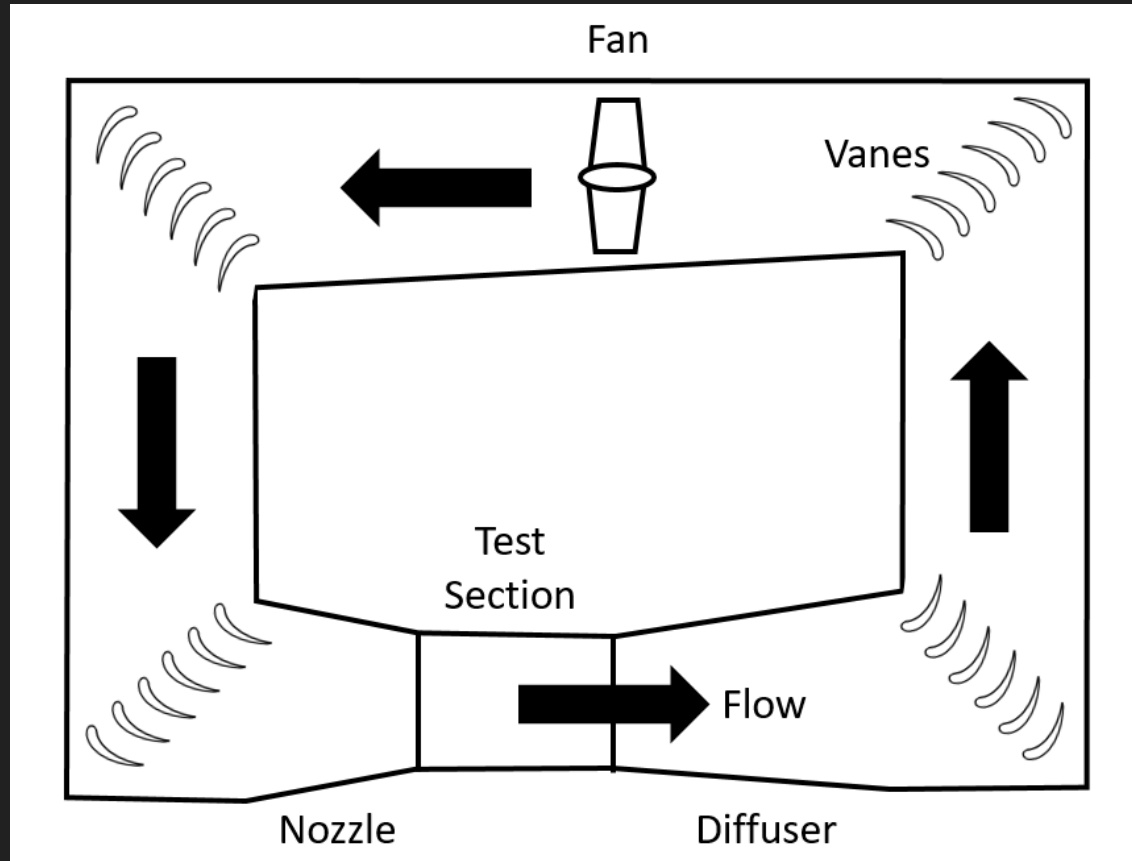

# Our Wind Tunnel

Design considerations:

Space constraints  
16 ft. long,  
6 ft. tall,  
3 ft. wide.

Test section:

Speed: 100 mph  
29 in. long,  
9.5 in. tall,  
14 in. wide.

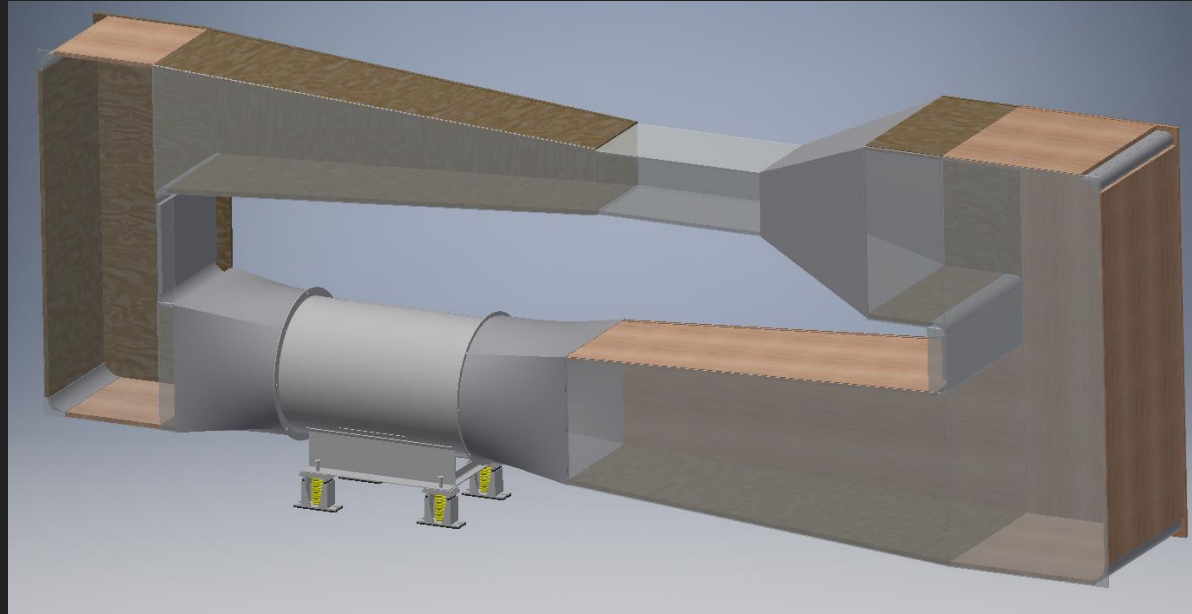

# Initial Design

Initial design completed by  
Jonathan Jaramillo

Corner vanes researched by  
Dan Eager

Nozzle researched by  
Jeremy Martin

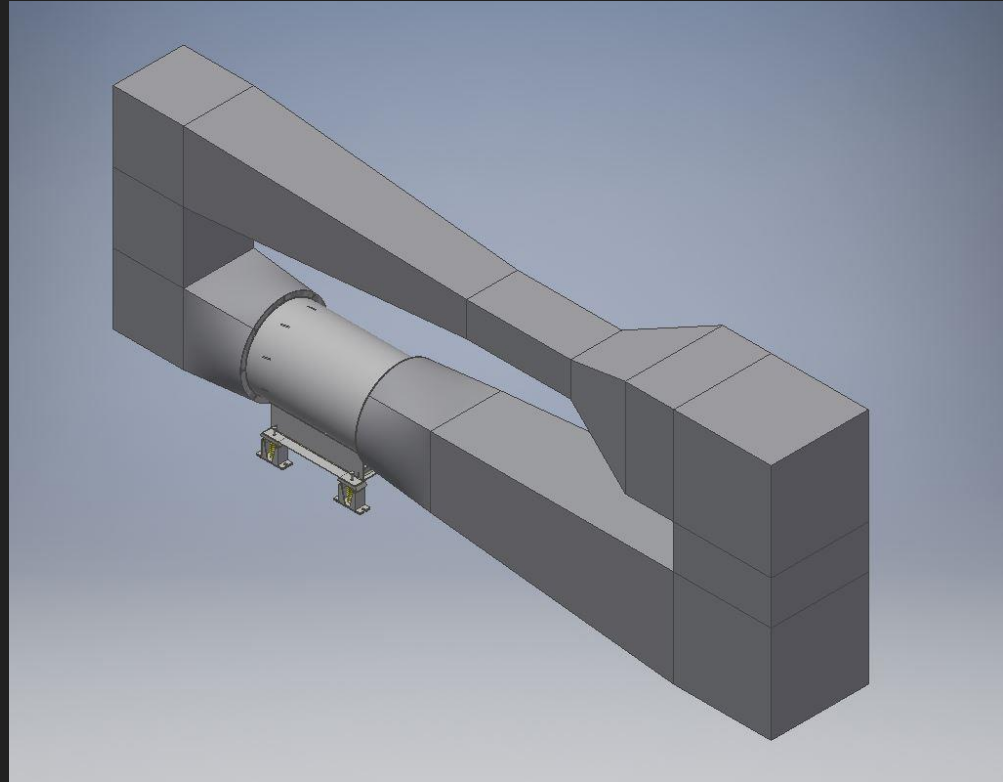

# My Work: Vanes and Diffusers

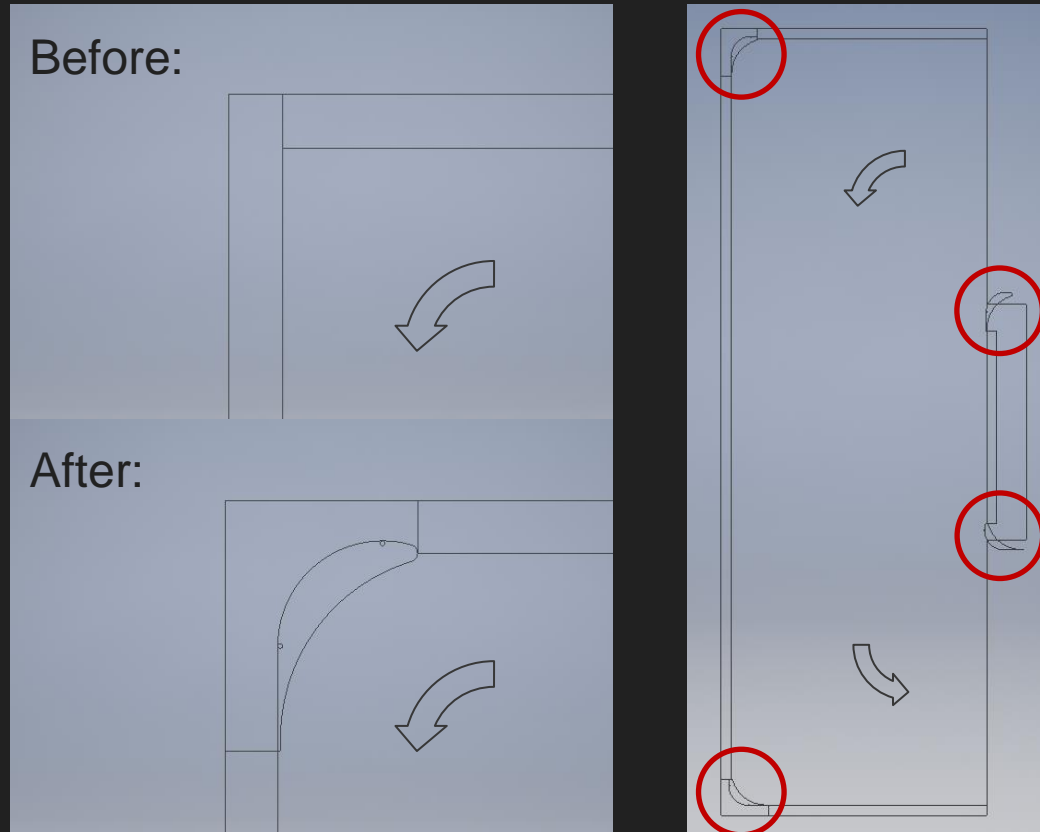



# My Work: Vanes and Diffusers (Contd.)

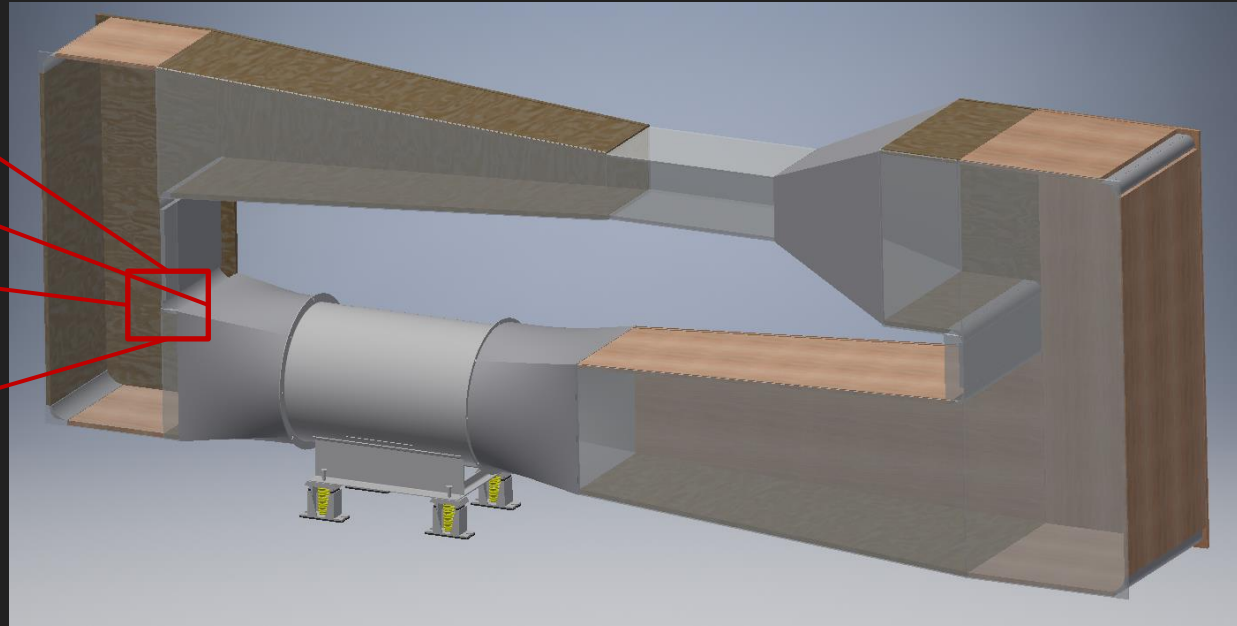
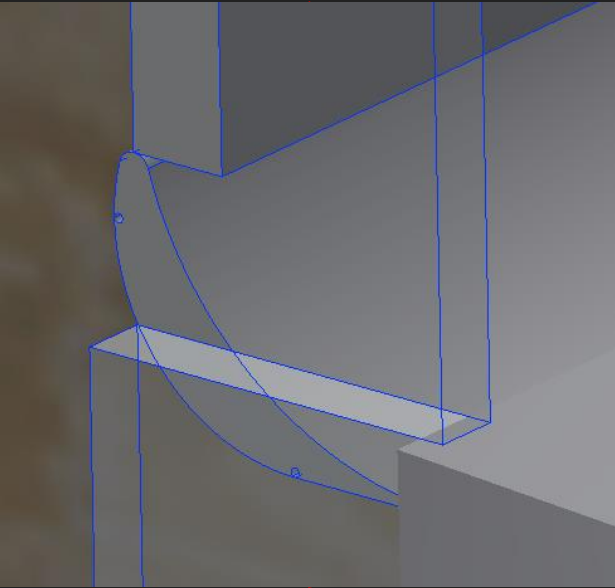

# My Work: Vanes and Diffusers (Contd. 2)

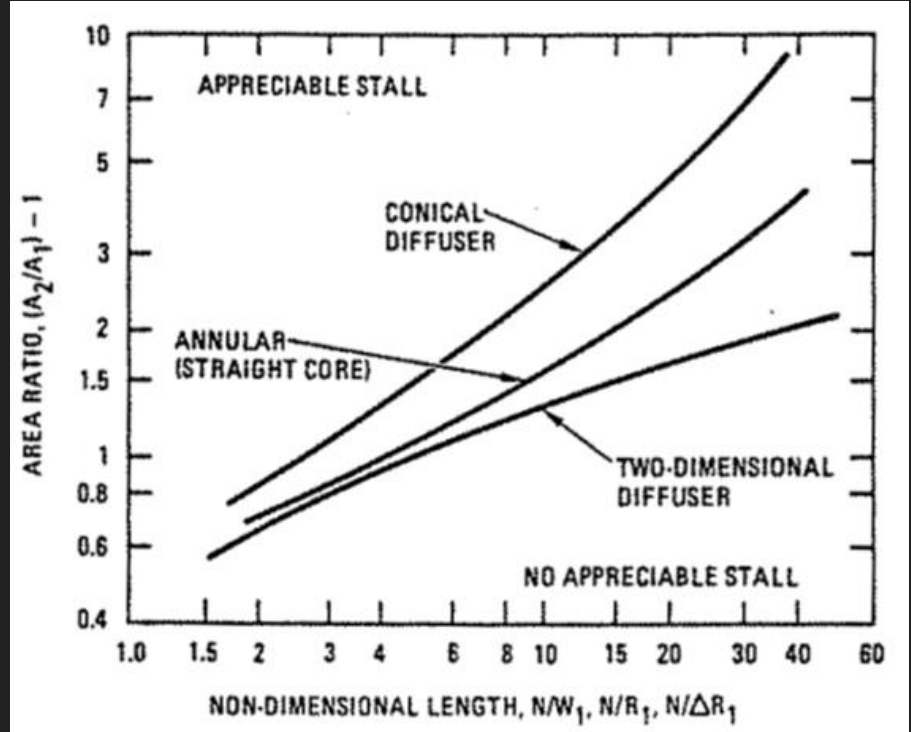
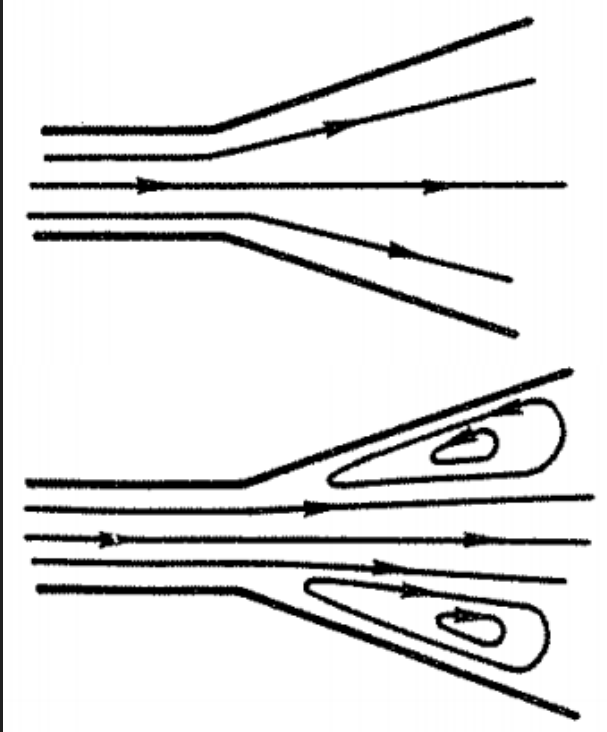

# Construction Progress



# Conclusions

Much more work to be done

Complete:

One diffuser, small corners

Incomplete:

Smaller diffuser, test section

Larger corners, nozzle

Further research into nozzle, test section

Shape of nozzle

Recording data from object in test section

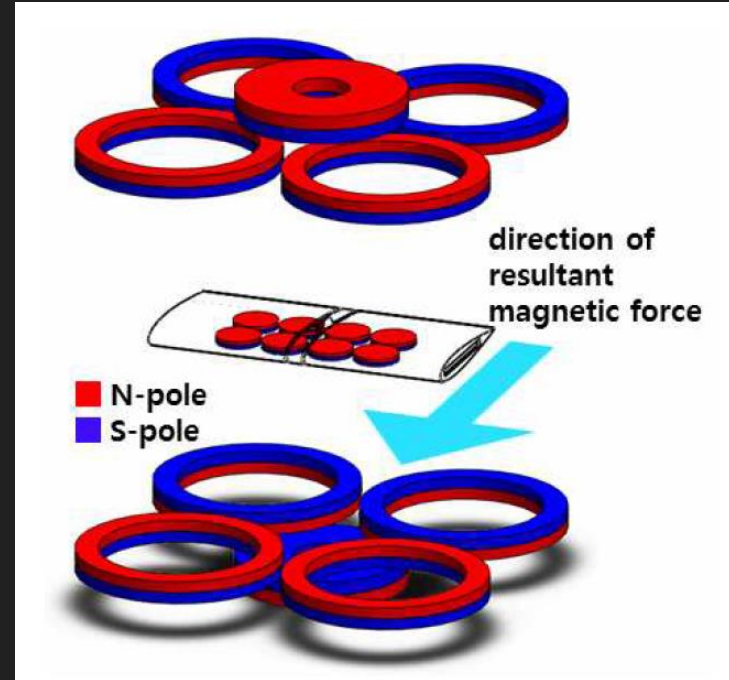

# Acknowledgements

Dr. Aikens

Houghton College

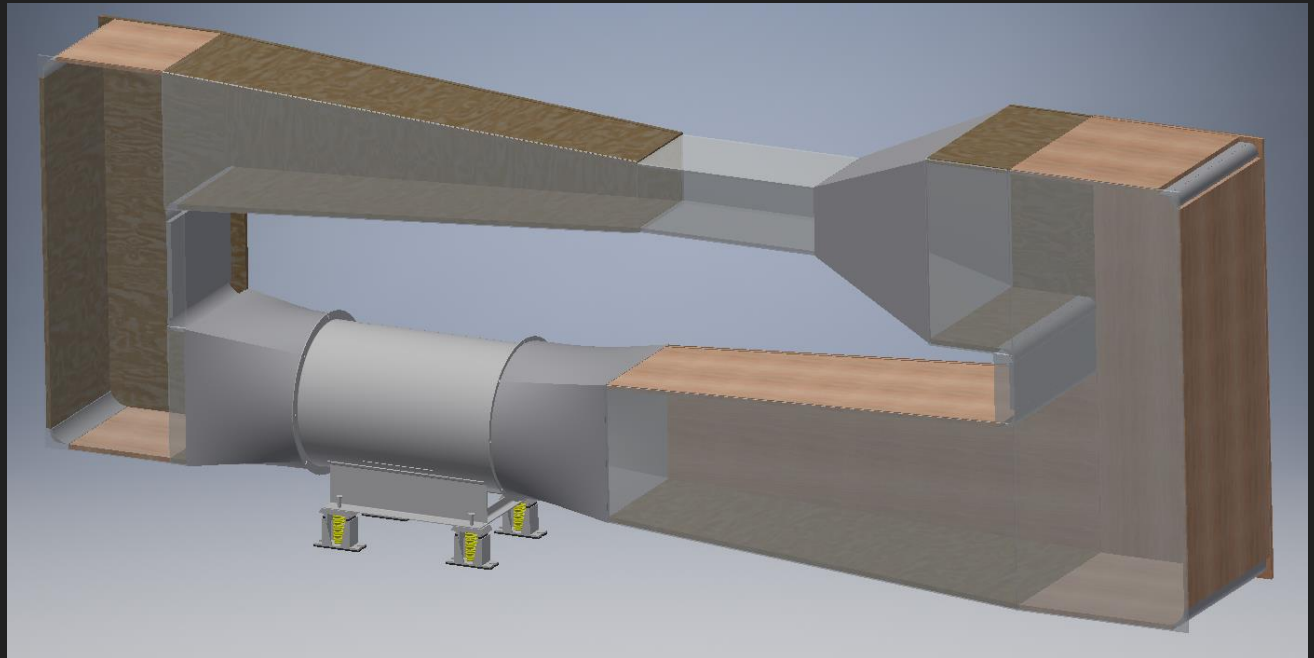

# References

- D. D. Baals and W. R. Corliss, *Wind Tunnels of NASA* (U.S. Government Printing Office, Washington, D.C., 1981).
- W. T. Eckert, K. W. Mort and J. Jope, NASA TN D-8243 (1976).
- R. D. Blevins, *Applied Fluid Dynamics Handbook*, (Van Nostrand Reinhold Co., New York, 1984).
- D-K Lee, J-S Lee, J-H Han, and Y Kawamura, *J. Mech. Sci. and Tech.* **27** (2013).
- J. D. Jaramillo, B.S. Thesis, Houghton College, 2017.
- D. J. Eager, B.S. Thesis, Houghton College, 2018.
- J. S. Martin, B.S. Thesis, Houghton College, 2019.

# History and Motivation

Frank Wenham (1824-1908)

- First wind tunnel in 1871

Wright Brothers

- Open-return wind tunnel
- Practically a box
- Possibilities are endless

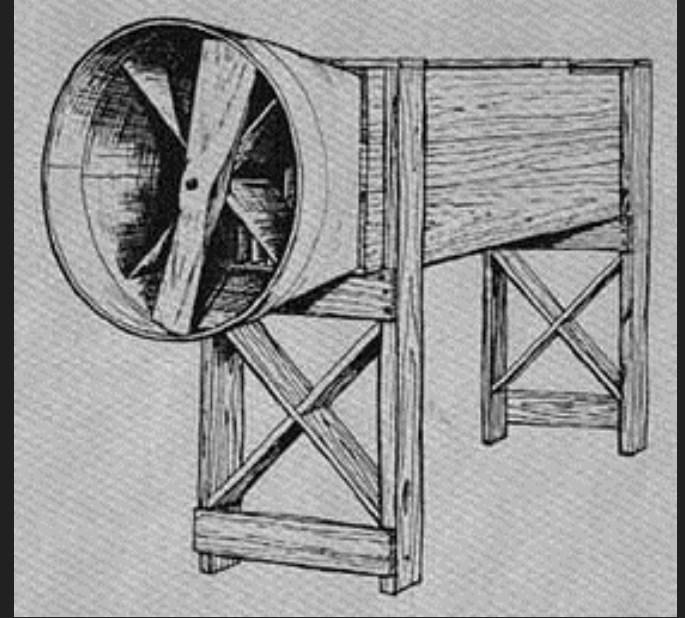

# Governing Equations (Non-Dimensionalized)

Continuity equation and Navier-Stokes equations:

$$\frac{\partial \rho'}{\partial t'} + \frac{\partial}{\partial x'_k} (\rho' u'_k) = 0$$

$$\frac{\partial(\rho' u'_j)}{\partial t'} + \frac{\partial(\rho' u'_j u'_k)}{\partial x'_k} = \frac{\partial}{\partial x'_i} \left\{ -p' \delta_{ij} + \mu \left( \frac{\partial u'_i}{\partial x'_j} + \frac{\partial u'_j}{\partial x'_i} - \delta_{ij} \frac{2}{3} \frac{\partial u'_k}{\partial x'_k} \right) \right\}$$



# Experimental/Computational Fluid Dynamics

## Similarity Parameters

Reynolds number

Mach number

Other numbers

$$\text{Re} = \frac{\rho_{\infty} U_{\infty} L}{\mu_{\infty}}$$

$$\text{M} = \frac{U_{\infty}}{a_{\infty}} = \frac{U_{\infty}}{\sqrt{\gamma R T_{\infty}}}$$

# Empirical Correlations

- Loss coefficients
  - Must minimize
- General form:

$$K_i = \frac{\Delta p_T}{q}$$

Image here?

Maybe general wind tunnel, to show components better.

# Our Corner Vanes

